

STANDARD MODEL SPECIFICATIONS

Dranjer™ Sump and Floor Seals

Model JS15 SUMP LARGE

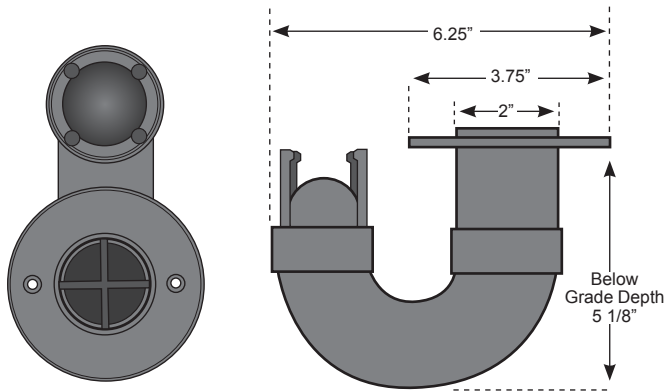

Fits into and becomes part of your sump cover. It is a one way valve that allows water to flow into the sump but prevents Radon Gas, soil gas, insects and odours from entering your living environment.

Installing the JS15 requires cutting a 2-inch hole in your sump cover. The JS15 sump valve then fastens to the underside of the sump cover using the alignment collar which protrudes around the top of the JS15.

Model JN6 DRAIN RETROFIT & NEW INSTALLATION

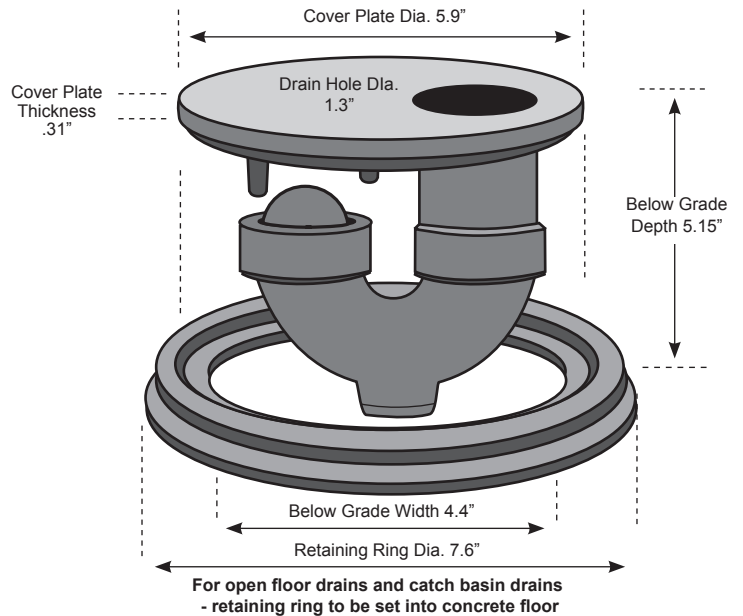

For open floor drains and catch basin drains
- retaining ring to be set into concrete floor

Model DR2 SMALL DRAIN RETROFIT

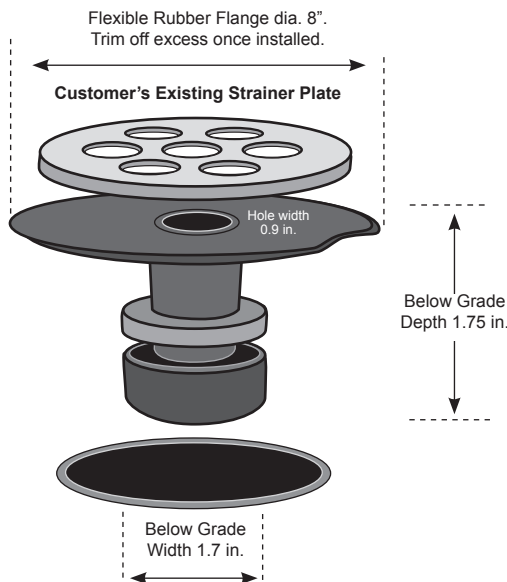

Model JR15 LARGE DRAIN RETROFIT

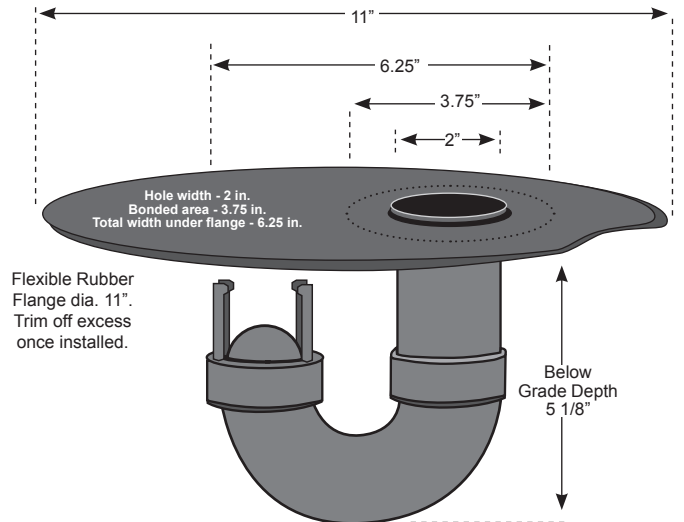

For large floor drains. The unit fits underneath the existing strainer plate and is held in place by friction (pinched between the strainer plate and the retaining ring) and by caulking.

Model FN2 DRAIN NEW INSTALLATION

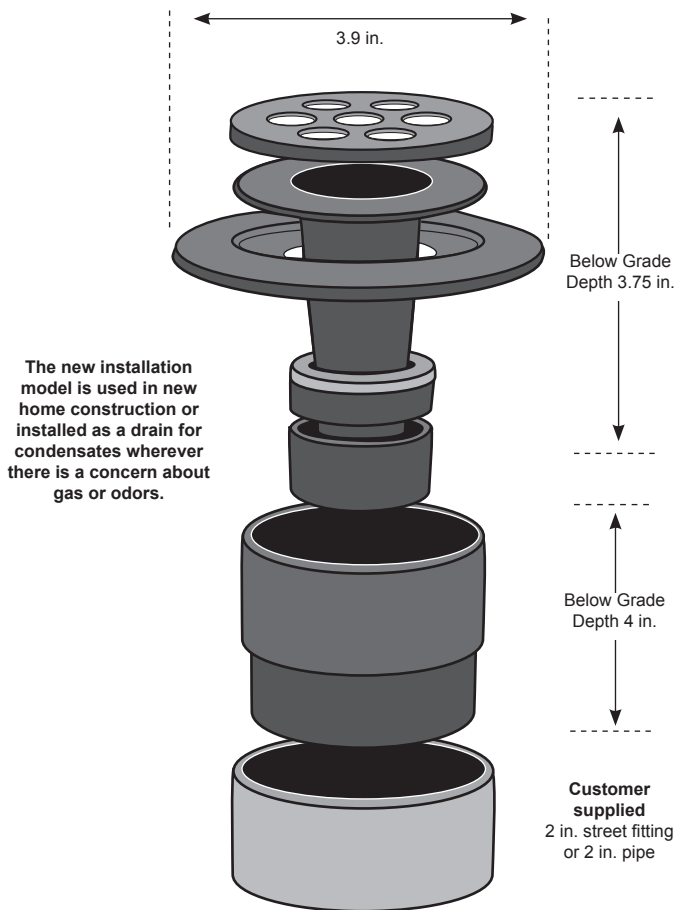

Model FR2 DRAIN RETROFIT

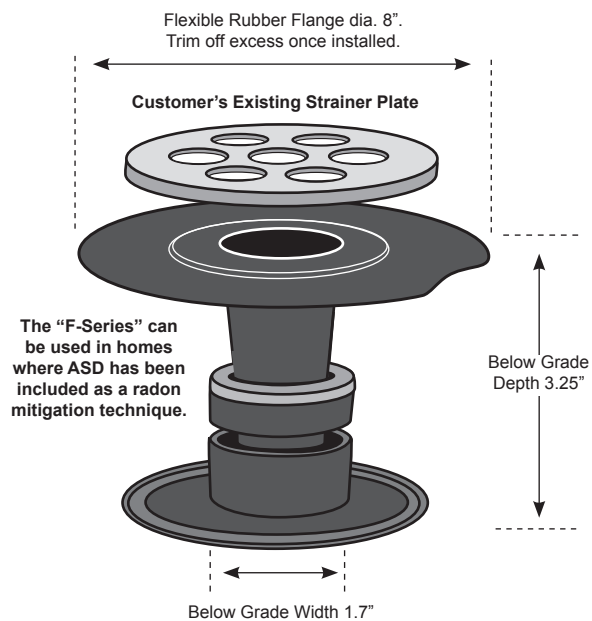

Model FS2 SUMP SMALL

